

## Universal Child-Footboard Design for Under-bone Motorcycle

Ruwaidy Mat Rasul<sup>1</sup>, Nurhikma Mat Yusof<sup>2\*</sup>, Siti Nurul Akmal Yusof<sup>3</sup> and Tuty Liana Medali<sup>4</sup>

<sup>1</sup>*Industrial Design Innovation & Sustainability Research Group, Faculty of Innovative Design and Technology, Gong Badak Campus, Gong Badak, 21300 Kuala Nerus, Terengganu Darul Iman, Malaysia*

<sup>2</sup>*College of Creative Arts, UiTM Cawangan Melaka, 78000 Alor Gajah, Melaka, Malaysia*

<sup>3</sup>*CADCAM TECH Research Group, Faculty of Innovative Design and Technology, Universiti Sultan Zainal Abidin, Kampus Gong Badak, 21300, Kuala Nerus, Terengganu, Malaysia*

<sup>4</sup>*Universiti Kuala Lumpur, 1016, Jalan Sultan Ismail, 50250 Kuala Lumpur, Wilayah Persekutuan Kuala Lumpur, Malaysia*

### ABSTRACT

In many Southeast Asian countries, children frequently ride as pillion passengers on motorcycles. However, standard motorcycle designs are not adapted to children's physical dimensions, increasing the risk of injury due to poor stability and unsupported posture. In Malaysia, this practice persists due to economic and practical reasons, despite evident safety concerns. This study addresses the design gap by introducing a child-friendly motorcycle footboard tailored for under-bone models. Developed through a user-centered design process, the footboard was evaluated using SolidWorks simulations. Von Mises Stress analysis revealed a maximum stress value of 213.5 MPa, and Contour Displacement analysis showed a maximum deformation of 2.185 mm; confirming mechanical stability and structural resilience. To complement simulation results, the prototype underwent ISO accredited laboratory tests, including break-load and salt-spray analysis, verifying its durability under operational stress and environmental exposure. These findings affirm the footboard's capability to enhance riding safety and provide peace of mind to parents transporting children. The design supports everyday use without compromising the motorcycle's performance. Furthermore, this research aligns with SDG 3.6, which aims to reduce global road traffic injuries by 50% by 2030, demonstrating how thoughtful design innovation can contribute to public health and safer mobility solutions for vulnerable users.

#### ARTICLE INFO

##### Article history:

Received: 13 January 2025

Accepted: 02 February 2026

Published: July 2026

DOI: <https://doi.org/10.47836/AC.19.S1.PAPER01>

##### Email addresses:

[ruwaidyrasul@unisza.edu.my](mailto:ruwaidyrasul@unisza.edu.my) (Ruwaidy Mat Rasul)

[hikmayusof@uitm.edu.my](mailto:hikmayusof@uitm.edu.my) (Nurhikma Mat Yusof)

[snakmalyusof@unisza.edu.my](mailto:snakmalyusof@unisza.edu.my) (Siti Nurul Akmal Yusof)

[tutylianamedali@gmail.com](mailto:tutylianamedali@gmail.com) (Tuty Liana Medali)

\* Corresponding author

*Keywords:* Children's footboard, Child Pillion, Industrial Design, Universal Design, Under-bone Motorcycle

### INTRODUCTION

Being the most practical mode of transportation for low- and middle-income countries, motorcycles have rapidly

increased in number on the roads, leading to negative consequences such as injuries and even fatalities (Rodrigues, 2018; Yousif et al., 2020; Peličić et al., 2024). Moreover, motorcyclists are 26 times more likely to be involved in an accident than car passengers (Norzamira, 2021; Diyana et al., 2017). The World Health Organisation reported that the lives of 1.3 million people are cut short due to a road traffic crash every year. With total of 54 million motorcycles recorded in 2006, China holds the most significant annual production of motorcycles with 22 million units. However, India has an estimated 37 million motorcycles and has become the largest country using them for easy transportation (ASEAN Stats Data Portal [ASDP], n.d.; Shajith et al., 2019). On the other hand, Malaysia has an average of 1000 units of new registered motorcycles each year. Within the past five years, the numbers of registered units were 31,214 in 2019, 32,378 in 2020, 33,570 in 2021, 35,992 in 2022, and 36,626 in 2023 (ASEANStatsDataPortal, 2024).

In many low- and middle-income countries, motorcycles serve as a dominant mode of transport due to their affordability and accessibility, especially in urban and semi-urban areas. Despite their practicality, motorcycles are a major contributor to road traffic injuries, with children as pillion passengers being among the most vulnerable.

In Malaysia, as reported by Malaysian Institute of Road Safety Research (MIROS, 2017), motorcycles are widely used by families, especially in suburban and rural areas with limited public transport. A MIROS study reported that over 30% of school-going children are regularly transported as pillion passengers. Furthermore, an observational survey in Selangor (2013) revealed many children resting their feet on hot or unstable parts such as exhausts (Paiman et al., 2013). Additionally, nearly 30% of motorcycles carried more than one child passenger. The absence of regulatory or commercial safety products for children in Malaysia further compounds the risk, as identified by Sivasankar et al. (2014), who also noted the prevalence of lower-limb injuries and the urgent need for design solutions such as foot supports and backrests.

Moreover, recent registration trends indicate growing reliance on motorcycles, with over 36,000 new units registered in 2023 alone (ASEANstats Data Portal, 2024). Yet, local manufacturers have not addressed the unique safety needs of child pillion riders. However, most motorcycles are designed for adults, and the standard foot peg position is often unreachable for children under 12 years old. Many resort to placing their feet on unsafe parts like exhausts or engine casings, increasing the risk of burns and injuries (Fatimah et al., 1997; Mohamed Zaki et al., 2022). Despite the prevalence of this practice, no commercial product currently addresses this safety gap. This highlights an urgent need for design interventions that enhance foot support and stability for young pillion riders.

While existing research often addresses general motorcycle safety, there is limited focus on child-specific design solutions, particularly regarding foot support and riding stability. Recent design-oriented studies have begun addressing child pillion safety. As such, Koetniyom et al. (2018) used crash test simulations in identifying an injury pattern among child passengers, thereby underscoring the need for structural support, while Zaki et al. (2022) collected Malaysian child anthropometry to inform suitable footboard dimensions. This study addresses this gap by designing and validating a child-friendly footboard that enhances safety and reduces the risk of injury during motorcycle travel.

In addition, it offered daily transportation for errands like dropping kids off at school. These transportation become choices of Malaysian families, particularly those in low- to middle-income brackets, are often shaped by economic necessity. From the perspective of transport sociology, this reflects the influence of structural constraints such as limited public transportation, affordability, and accessibility. As a result, under-bone motorcycles are commonly used for family mobility, even when this involves safety trade-offs. This study also draws on the principles of ergonomic design and design for safety, which emphasize the anticipation of potential hazards and the alignment of product features with user characteristics, such as children's anthropometry and existing motorcycles. These frameworks guide a child-centered design approach that aims to prevent injury through structural intervention rather than behavioural adjustment alone.

On the other hand, new safety initiatives and programmes are required for children's motorcycle safety. These efforts should include not only awareness campaigns and regulatory updates but also engineering countermeasures (Sivasankar et al., 2016).

Due to the ease of care for children riding in the back, there is an increased risk of road accidents because of the disparity in size between the children and the motorbike (Fatimah et al., 1997; Tosi et al., 2021). Studies have shown that these youthful hordes were not steady when riding along. This is because the foot pegs on the current generation of under-bone motorcycles do not have a feature that makes them a child-friendly experience. As described by Mohamed Zaki et al. (2022), the child's uncomfortable sitting position may be a factor associated with the use of these underbone motorcycles, despite their engine displacement being under 250 cc. In addition, most children's feet hang because they cannot reach the foot peg; as a result, they tend to rest them on other reachable surfaces, such as the exhaust or engine parts (Rasul et al., 2019). When the engines are running, these parts become extremely hot.

Currently, no device on the Malaysian market secures a child's foot while riding a bike. The reason for this is that local riders do not require the goods and are not as informed about the issue of motorcycle safety (Cheng et al., 2011). Furthermore, local producers are

not taking the initiative to create and manufacture any kind of product, including pillion footboards. Designers are not permitted to showcase their answers to challenges regarding product design, as well as the existing issues with standard foot pegs, which are crucial for motorcycle riders. In addition, children's body sizes are inappropriate for pillion riding on current motorcycles due to the pegs' design and features. This is because the children's anthropometry and the height level of the present motorcycle pegs do not match, which could cause considerable damage if a child is left hanging from a motorcycle.

The main concern in this study is the inadequacy of typical motorbike footrests, which are intended for adults and cannot be reached by children. Furthermore, there is a scarcity of specific footrest items designed for youngsters who ride as pillion passengers. There is a lack of footrests specifically designed for young passengers, resulting in the risk of injury as children's legs are more vulnerable to being struck or caught in the motorcycle's rear wheel (Mohamed Zaki et al., 2022). Thus, this study focuses on the practical design of a child-friendly motorcycle footboard that improves body stability on the bike. It also entails using a standardised testing approach to verify the finalised motorcycle footboard design. Its goal is to design and build a pillion footboard to lessen the possibility of children's feet getting into the back of the motorbike tyre by increasing stability. Furthermore, the design rationale for the proposed footboard is based on the 1959 Road Traffic Rules, which requires the provision of adequate footrests for all passengers to ensure vehicle stability. Although, Department of Standards Malaysia (DSM, 2006) has outlines MS ISO 11838:2006 as a standard ergonomic configuration for motorcycle controls, the standard largely considers adult sizes only. By integrating the technical principles of UN Regulation No. 129, under the United Nations Economic Commission for Europe (UNECE, 2012) which emphasizes the specific protection of children in transportation, this study bridges the gap between adult-centric motorcycle manufacturing and the specific ergonomic needs of children. On the other hand, the pillion rider faces less risk. Aside from that, the final design will undergo lab testing to confirm its utility.

## **METHODOLOGY**

### **Design Development Process**

The design process began with conceptual sketches based on child anthropometric data collected from local Malaysian school-age populations (ages 6–12), including leg length and foot size references from previous studies. Initial ideas were translated into CAD models using SolidWorks 2020 SP5, with attention to fit, reach, and comfort for children under 12. The P.Jacq™ footboard was refined iteratively across four concept stages, incorporating input from product design consultants and informal feedback from parents and motorcycle users.

## Participant Inclusion

While no human subjects were used in live testing, this design was informed by secondary anthropometric data. Selection of target dimensions was based on percentile ranges (5th–95th percentile) for Malaysian children. Informal consultations were also conducted with parents and motorcycle workshop technicians to understand common pillion riding habits and design needs.

Table 1  
*Group of participants with role of study*

| Group       | Sample Size (N) | Selection Criteria                 | Role in Study                    |
|-------------|-----------------|------------------------------------|----------------------------------|
| Parents     | 10              | Regularly transport 6–12 years old | User requirement identification  |
| Technicians | 5               | >10 years experience               | Technical feasibility & mounting |
| Consultants | 2               | Industrial Design background       | Aesthetic & ergonomic refinement |

Feedback from parents, technicians, and users was analysed using a thematic analysis approach. This process involved transcribing key statements, generating initial code, and grouping the code into recurring themes related to Usability, Safety, and Installation Feasibility. This process ensured that design iterations were based on documented user needs.

## Data Types and Method Integration

The design phase employed a qualitative iterative design approach, while the quantitative data were obtained through simulations (Von Mises, displacement) and prototype testing under controlled conditions.

## Analysis Techniques and Theoretical Justification

Finite Element Analysis (FEA) was used in SolidWorks to perform Von Mises Stress and Displacement Analysis, chosen due to their relevance in evaluating ductile failure in thermoplastic materials. Design for Safety (DfS) principles guided simulation load selection to reflect real-world child usage, with force loads approximated at 30–50 kgf based on maximum child stepping force and additional load during riding turns or emergency braking.

## Testing Environment and Conditions

3D modelling was conducted in SolidWorks 2020, simulating both static and dynamic loads relevant to Malaysian road conditions. For environmental validation, prototype testing was performed in the SIRIM QAS engineering lab, a certified testing facility. The Salt Spray Test followed ASTM B117-19 requirements, simulating corrosive outdoor conditions explicitly adopting the Standard Practice for Operating Salt Spray (FOG) conclude in the SIRIM Test Report No. 2022MAD269, while the Break Load Test simulated step and crush forces expected during normal use.

## **Limitations and Uncertainties**

This study does not include live usability trials with children due to ethical limitations. Anthropometric inputs were taken from prior validated datasets and not measured firsthand. Additionally, simulation conditions do not fully replicate all possible stress orientations or dynamic motorcycle riding conditions (e.g., vibration, cornering). Future work may include real-time use validation and integration with vehicle compliance standards for pillion safety devices.

## **RESULT AND ANALYSIS**

### **3D Software Analysis**

The P.Jacq footboard design was analyzed using 3D software to find any possible weaknesses. The investigation showed that the footboard's attachment points to the motorcycle; Screw Hole 1 (Item 3) and Screw Hole 2 (Item 4) were the most prone to distortion. Under simulated loading circumstances, the stress concentrations in these sites were higher, suggesting a higher probability of deformation or failure in these regions (Figure 1). The study uncovered these weak locations and emphasized the importance of the displacement observed in the Footrest Bracket (Item 1). This component's integrity is essential since it immediately supports the pillion's feet when riding a motorcycle. It is imperative to act Footrest Bracket receives careful attention during design optimization since any undue displacement there could jeopardize the pillion rider's stability and safety. The design of the footboard can be developed to enhance its durability and improve safety by observing the patterns of displacement and stress distribution. This will guarantee that the footboard satisfies all performance requirements in real-world scenarios.

The upgraded models have seen significant design modifications, as shown in Figure 2, emphasizing the improvement of the product's usability. The fundamental idea of simple assembly has stayed the same, so customers may install the footboard quickly and easily without needing complicated steps or specialized tools. Furthermore, the footboard of the design is now foldable and adjustable, providing more versatility to suit various rider preferences and storage requirements.

Although the footboard's aesthetic appeal has improved with a more modern appearance and functional enhancements implemented. The Footrest Bracket was designed to have a smaller surface area. This modification reduces total weight and preserves structural integrity, guaranteeing that the footboard remains solid and trustworthy during usage. These enhancements of the new models are more user-friendly, adaptable, and efficient, addressing functional and stylistic requirements.

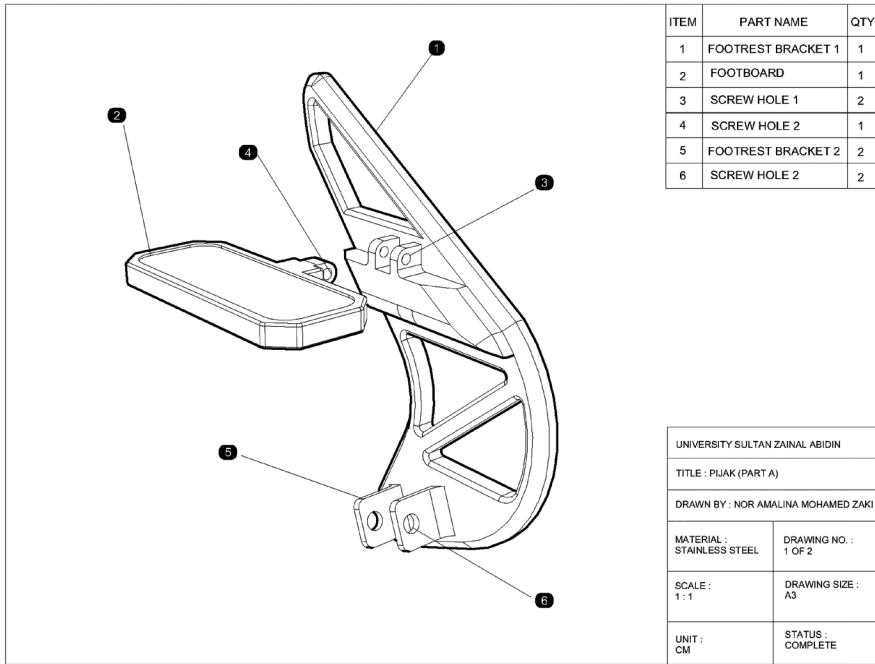

Figure 1. Exploded view of P.Jacq™

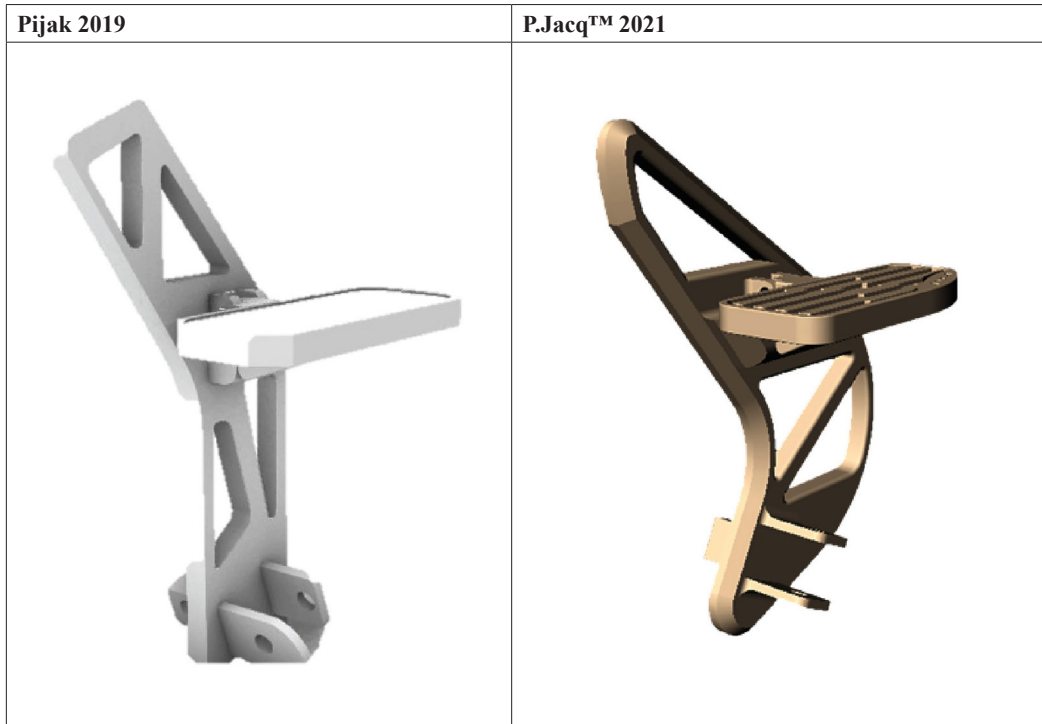

Figure 2. The comparison between Pijak 2019 and P.Jacq™ 2021

### Von Misses Stress Analysis

As shown in Figure 3, Screw Hole 2 is the most critical area of the universal footboard since it receives the most pressure when supporting a pillion rider. This screw hole is subjected to considerable stress due to its role in attaching the footboard to the motorcycle and its constant movement while in use. Consequently, Screw Hole 2 design improvement with the highest level of durability to withstand these demanding conditions.

According to the stress study performed using Von Mises criteria, Screw Hole 2 has a maximum stress value of 175.4 MPa under load, as shown in Figure 4. This figure represents the peak stress concentration in the location, emphasizing the significance of reinforcing this footboard section to avoid deformation or collapse over time. The research suggests that each footboard side can hold and carry a maximum load of 1788.58 kgf/cm<sup>2</sup>. This high load-bearing capacity emphasizes the importance of robust design and material selection to ensure that the footboard can consistently carry the weight of the pillion rider in various operating situations. Addressing these essential elements can improve the footboard's longevity and safety, resulting in long-term performance and rider security.

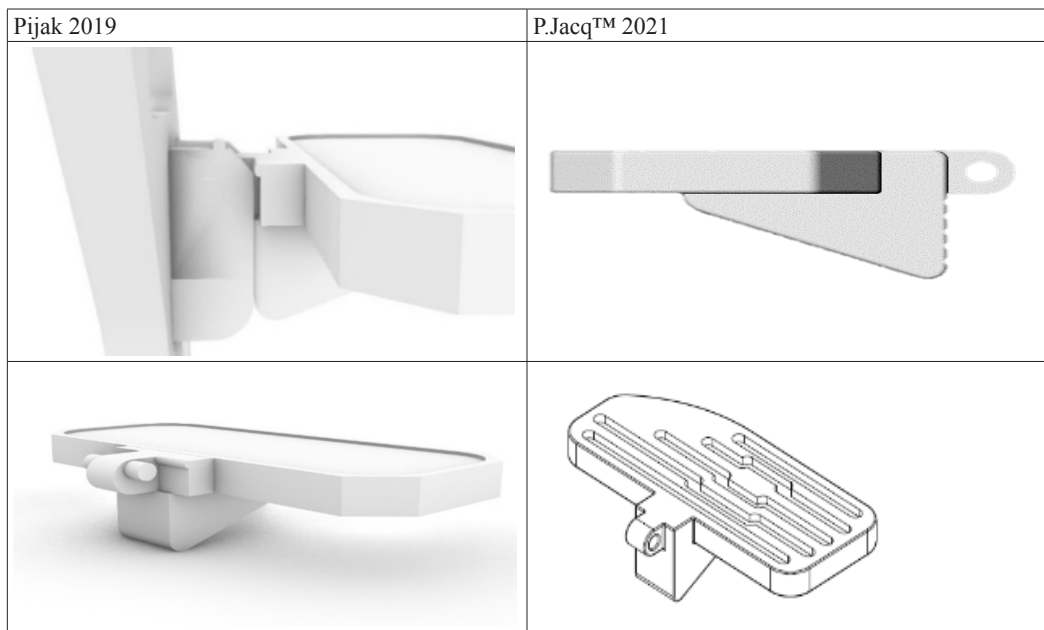

Figure 3. The comparison of screw hole 2 between Pijak 2019 and P.Jacq™ 2021

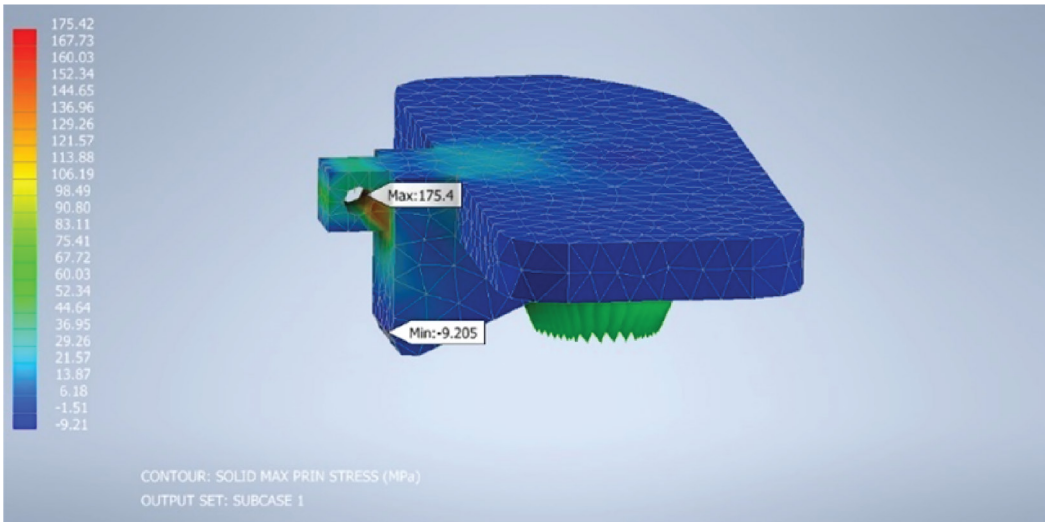

Figure 4. Comparison of screw hole 2 on P.Jacq™ 2021 model

In contrast, the study of Footrest Bracket 1 found a maximum contour displacement of 2.185 mm, as illustrated in Figure 5. This level of displacement is especially significant since it shows that the bracket can flex enough to absorb shocks and reduce vibrations while retaining structural integrity. This flexibility is an important safety factor since it ensures the bracket can protect a child’s foot from potential contact with a moving tyre, enhancing overall safety. The outcomes of this displacement analysis gave useful insights, resulting in further modifications to the footboard’s structural design. The revised and improved design focuses on improving safety and the footboard’s general practicality through the combination of rigidity and flexibility, making it a more reliable bracket and user-friendly in real-world situations.

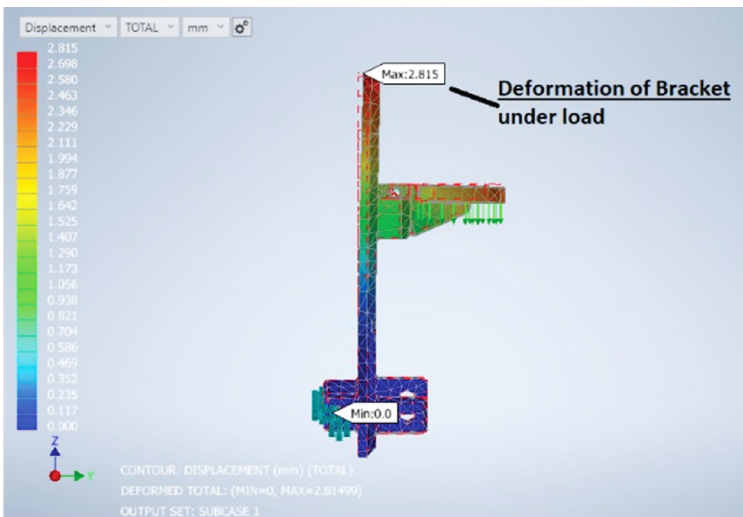

Figure 5. Contour displacement of footrest bracket deformed

Figure 6 displays the finalized design of the P.Jacq™ footboard. After confirming this design using 3-dimensional software analysis, the next critical step is to create a real prototype. This physical prototype represents the ultimate design, allowing for real-world testing and validation. Iron casting is the material chosen as the preferred prototype production method due to its capacity to recreate delicate design elements (Bussell, 2013; Sudhakar, 2022). Although iron casting is a low-cost method for creating personalized prototypes, it can be costly, particularly given the precision required in the production process. In contrast to cast iron and brass, the potential benefits of combining these materials are considered similar and practical for prototyping. However, this approach proved primarily due to the prohibitive cost associated with the highly skilled workmanship required for the handmade production of brass items in contemporary manufacturing, as described by Mohamad and Walker (2019). With that, cast iron appears to be the most suitable material. Regardless of the price, developing a high-quality prototype is critical because it allows for comprehensive laboratory testing to ensure that the device satisfies all safety, durability, and performance standards. Prototype laboratory testing is an essential stage in development because it provides empirical data to assess the design's performance under various operational situations. This testing will determine that the P.Jacq™ footboard satisfies standards and is ready for mass production, ensuring the finished product is reliable and safe for end users.

The earliest stage of prototype development involves the preparation of precise technical drawings. This technique requires two types of drawings: casting and machining (Figure 7). The Casting Drawings serve as a blueprint for the casting process, directing the creation of the prototype's basic structure from molten iron. These designs ensure that the general shape and significant design components are fully reconstructed and built throughout the casting process. Machining Drawings were used to apply and complete the cast prototype. Due to the inherent limitations of bespoke iron casting (such as excess material or rough surfaces), these drawings are crucial for determining the precise adjustments required to meet the final design criteria. Machining involves removing extra material and fine-tuning the prototype to precision tolerances, ensuring the design's functional and aesthetic features are displayed. With the results, the dual process of casting and machining allows for an important level of customization and precision in the prototype, laying the groundwork for additional testing and eventual production.

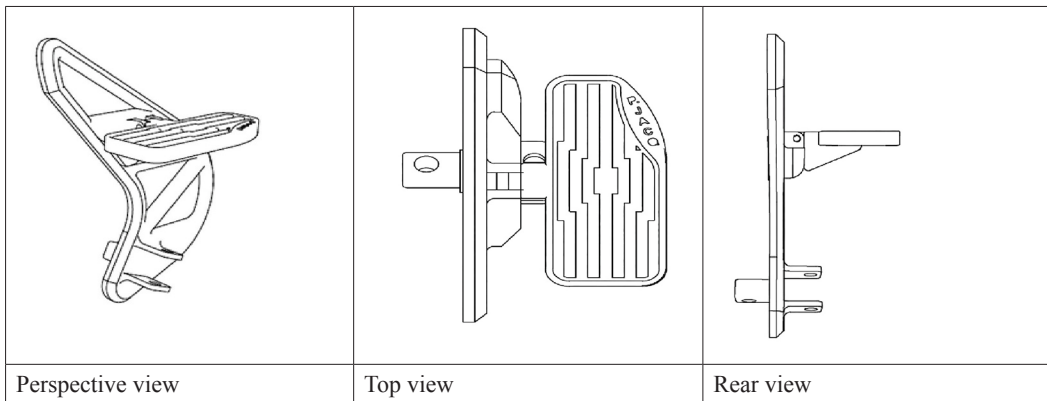
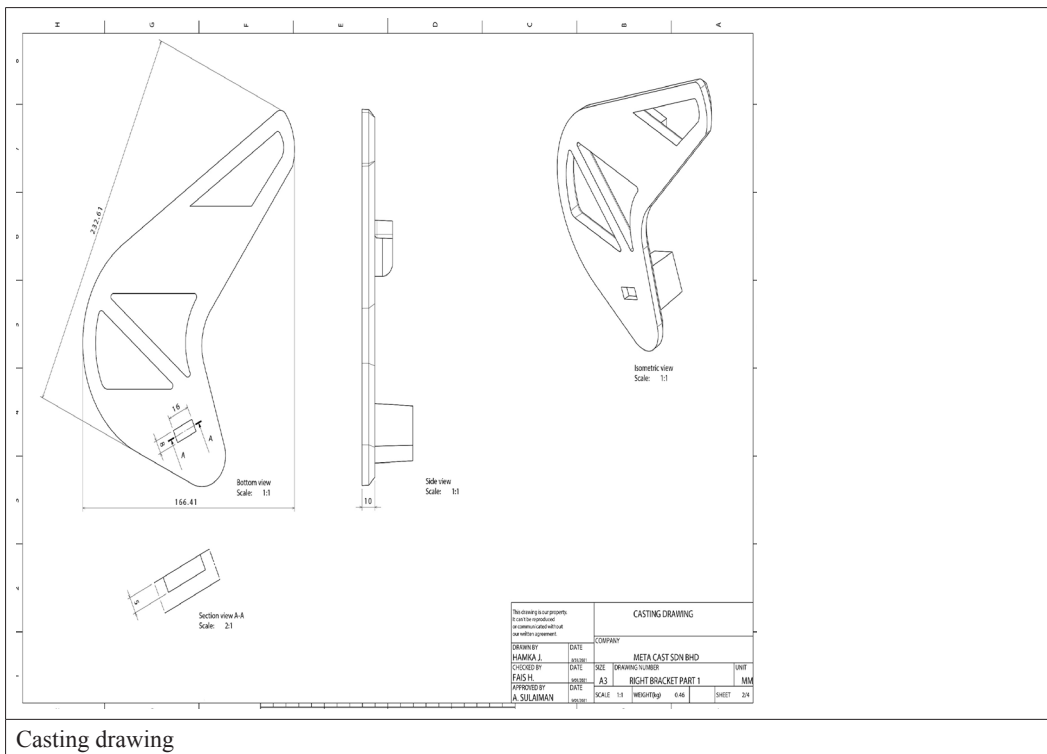

Figure 6. Finalization of P.Jacq™ design

A pair of footboard prototypes has been submitted to SIRIM Engineering Lab Test for further testing. This submission is a crucial stage in the validation process because SIRIM QAS International is a recognized authority on engineering standards and certifications. These laboratories will conduct rigorous testing to assess the performance, safety, and durability of the footboard in various scenarios. Figure 8 depicts the prototypes prepared for testing, emphasizing their preparedness for evaluation. This step is critical for confirming that the footboards meet regulatory criteria and work reliably in real-world circumstances before going into mass production.





was 3054.78 N, resulting in approximately 311.7 kgf. This higher figure represents the footboard's ultimate load-bearing capacity before structural failure. These measures are crucial for determining the footboard's capacity to endure operational stress while ensuring reliability and safety in real-world situations.

The test findings show that the footboard's failure occurred at the jointing area around Screw Hole 2. The breaking force at this vital region was 290.5 kgf, which is comparable to supporting a weight of 290.5 kg. The concentrated stress in this place caused material breakdown under the imposed load, confirming it as the design's weakest point (Figure 10). This conclusion is critical for understanding the footboard's structural constraints and will drive future design revisions to improve durability and ensure that the footboard can dependably manage the pressures encountered during operation.

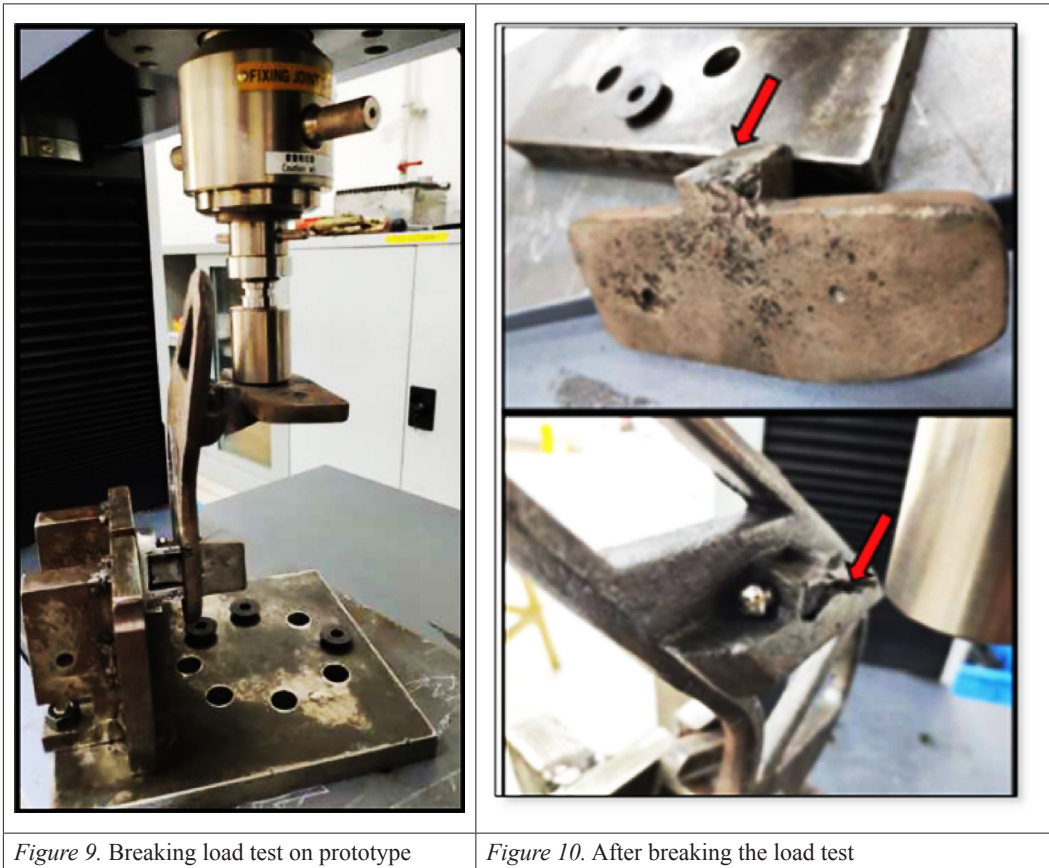

Figure 9. Breaking load test on prototype

Figure 10. After breaking the load test

### Salt Spray Analysis

To assess the corrosion resistance of the footboard materials, the ASTM-B117 2019 test was painstakingly set up with precise settings in compliance with the Standard Procedure for Operating Salt Spray (FOG). To replicate severe environmental conditions, the test

chamber was kept at a constant temperature of 35°C. A 5±1% sodium chloride (NaCl) concentration was employed in the salt solution to simulate the corrosive effects of saline surroundings. The solution's pH level was carefully regulated to guarantee precise testing conditions, ranging from 6.5 to 7.2. Figure 11 shows the sample (a) before and (b) after the salt spray exposure.

Furthermore, the atomizing solution's 1.0 to 2.0 ml volume was measured. This solution was collected hourly over an area of 80 cm<sup>2</sup>. This regulated saline mist dispersal ensured that the entire surface was exposed consistently. The material began to display red rust patches, as demonstrated in Figure 11(a), which indicate corrosion after continuously being exposed to these conditions for 72 hours. This result emphasizes the material's vulnerability to corrosion when exposed to salty conditions for an extended time, offering vital information for future material selection and protective coating considerations.



Figure 11. The sample before and after the salt spray exposure

## CONCLUSION

This study set out to address a critical gap in child motorcycle safety by developing and validating a universal footboard tailored for young pillion riders. The research aimed to mitigate injury risk caused by the mismatch between children’s anthropometry and adult-designed footrests on under-bone motorcycles. Specifically, the study aimed to design an ergonomically suitable and structurally safe footboard for children aged 6–12, evaluate its mechanical strength and durability through simulation and laboratory testing, assess its potential to reduce common foot placement hazards, and improve stability, and incorporate informal user feedback to enhance practical usability.

The design development process began with anthropometric data referencing Malaysian school-aged children (ages 6–12), focusing specifically on leg length and foot placement. Conceptual sketches were developed based on this data to ensure ergonomic compatibility. These sketches were then translated into 3D models using SolidWorks 2020 SP5 and refined through four iterative stages. Key design criteria included stability, safety, ease of mounting, and comfort for the target age group. Feedback from parents, motorcycle technicians, and everyday users helped shape the final form of the P.Jacq™ footboard, emphasizing practical utility and child-friendly usability.

Table 2  
*The P.Jacq™ footboard compares with the standard footpeg*

| Feature        | Standard Footpeg | P.Jacq™ Footboard            |
|----------------|------------------|------------------------------|
| Target User    | Focus for Adults | Children Friendly            |
| Support Area   | Minimal (<20 cm) | Large Platform (>150 cm)     |
| Material       | Steel/Rubber     | Iron Cast                    |
| Safety Feature | Textured Surface | Anti-slip surface            |
| Affordability  | Included         | Low-to-Middle Income focused |

Based on the feedback from reviewers, the P.Jacq™ footpegs are generally comfort and more convenience to compared with a standard OEM footpegs. While all production footpegs are factory-setting for an adult user, they lack the child-specific rigid foot support required for the high-vibration environment of underbone motorcycles (Table 2).

Assess structural performance, Finite Element Analysis (FEA) was carried out using SolidWorks. The simulation modelled the footboard under a vertical load of 50 kg—representing a child’s average weight and stepping force—applied to the center of the platform. Results showed a maximum Von Mises stress of 213.5 MPa and a maximum displacement of 2.185 mm. The selected ABS material provided adequate strength and rigidity, ensuring that the footboard could safely withstand regular riding conditions without significant deformation.

For real-world validation, a full-scale prototype was fabricated and tested at SIRIM QAS International. The break load test assessed the footboard's structural integrity under pressure, with the prototype enduring more than 110 kg before any visible deformation occurred. Additionally, a salt spray test conducted in accordance with ASTM B117-19 standards simulated prolonged exposure to corrosive environments. After 96 hours in a controlled chamber, the footboard exhibited no visible corrosion or surface degradation. These results confirm that the P.Jacq™ footboard is not only mechanically robust but also environmentally resilient for long-term use in Malaysian road conditions.

The successful outcome of this study demonstrates that affordable, child-specific safety interventions can be practically integrated into existing motorcycle infrastructure. By combining human-centered design with validated engineering analysis, this research contributes to both product innovation and broader efforts to enhance child passenger safety. Future work may involve real-world usability trials, regulatory adaptation, and integration with other protective systems for two-wheeled vehicles.

Beyond its technical validation, the P.Jacq™ footrest has significant potential commercial value not only for local motorcycle accessory manufacturers but also for Original Equipment Manufacturers (OEMs) across Southeast Asia. For future research, it is recommended that large-scale field tests be conducted across a variety of regional terrains to observe the effects of long-term vibration and cross-cultural user behaviour. In addition, this study serves as a technical blueprint for regional regulatory bodies such as MIROS (Malaysia), AIS (Indonesia), and ASEAN NCAP to collaborate in establishing uniform safety standards for child-specific motorcycle accessories.

## ACKNOWLEDGEMENT

We would like to express our sincere gratitude to the Research Group of Industrial Design Innovation & Sustainability for their invaluable support. This research was made possible by generous funding from the *Dana Penyelidikan Pra-Pengkomersilan (DPP)* grant number: 2020 R0060

## REFERENCES

- ASEANStatsDataPortal. (2024, November 19). *Total number of registered road motor vehicles (in thousand)*. <https://data.aseanstats.org/indicator/ASE.TRP.ROD.B.005>
- Bussell, M. (2013). Cast iron. In *Construction Materials Reference Book* (pp. 45-63). Routledge.
- Cheng, A. S. K., Ng, T. C. K., & Lee, H. C. (2011). A comparison of the hazard perception ability of accident-involved and accident-free motorcycle riders. *Accident Analysis & Prevention*, 43(4), 1464-1471.
- Department of Standards Malaysia. (2006). *Motorcycles and motorcycle-rider kinematics—Vocabulary (MS ISO 11838:2006)*.
- Diyana, N., Karuppiyah, K., Rasdi, I., Sambasivam, S., Tamrin, S., Mani, K., Syahira, P., & Azmi, I. (2017). Vibration exposure and work-musculoskeletal disorders among traffic police riders in Malaysia: A review. *Annals of Tropical Medicine and Public Health*, 10(2).

- Fatimah, M., Osman, A., & Perubatan, F. (1997). The risk of road traffic accidents among primary school children in Kuala Terengganu. *The Medical Journal of Malaysia*, 52(4), 402-408.
- Koetniyom, S., Carmai, J., Kassim, K. A. A., & Ahmad, Y. (2018). Kinematics and injury analysis of front and rear child pillion passenger in motorcycle crash. *International Journal of Automotive and Mechanical Engineering*, 15(3), 5522–5534. Koetniyom, S., Carmai, J., Kassim, K. A. A., & Ahmad, Y. (2018). Kinematics and injury analysis of front and rear child pillion passenger in motorcycle crash. *International Journal of Automotive and Mechanical Engineering*, 15(3), 5522–5534. <https://doi.org/10.15282/ijame.15.3.2018.9.0424>
- Malaysian Institute of Road Safety Research. (2017). *Child safety on motorcycles in Malaysia: A national observation study*.
- Mohamad, S. A., & Walker, S. (2019). The International Conference on Islamic Civilization and Technology Management. In *Proceedings of the International Conference on Islamic Civilization and Technology Management* (pp. 04-1–04-5). Research Institute for Islamic Products and Malay Civilization (INSPIRE), Universiti Sultan Zainal Abidin.
- Mohamed Zaki, N. A., Mat Rasul, R., & Norzaman, N. Z. A. (2022). Pilot study: Identifying the suitable design of motorcycle footboard for children. <https://doi.org/10.4108/eai.24-8-2021.2315293>
- Norzamira, C. N. (2021, January 21). 223 kemalangan akibat fizikal jalan raya. *Berita Harian*. <https://www.bharian.com.my/berita/kes/2021/01/773051/223kemalangan-akibat-fizikal-jalan-raya>
- Paiman, N. F., Md Isa, M. H., Mohd Jawi, Z., Abdul Manan, M. M., & Radin Umar, R. S. (2013). *Safety helmet use rate and child pillion riders' characteristics in Selangor* (Research Report MRR 12). Malaysian Institute of Road Safety Research.
- Peličić, D., Ristić, B., & Radević, S. (2024). Epidemiology of traffic traumatism. *Sanamed*, 19(2), 233–238. <https://doi.org/10.5937/sanamed0-51914>
- Rasul, R. M., Medali, T. L., Abdullah, S. H. Y. S., & Endut, A. (2019). Design and development of universal pillion foot-board for underbone motorcycle. *International Journal of Engineering and Advanced Technology*, 9(1), 1004-1011.
- Road Traffic Rules 1959* [L.N. 166/1959] (Malaysia).
- Rodrigues, E. (2018). *Motorcycle use in the Americas: Measures to improve the safety of motorcycle riders*. Pan American Health Organization
- Shajith, S. L. A., Pasindu, H. R., & Ranawaka, R. K. T. K. (2019). Evaluating the risk factors in fatal accidents involving motorcycle—case study on motorcycle accidents in Sri Lanka. *Engineer*, 52(3), 33-42.
- Sivasankar, S., Karmegam, K., Bahri, M. T. S., Kulanthayan, S., Emilia, Z. A., Sadeghi, H. N., Haszeme, A. K., & Ya, S. M. (2016). Children Pillion Rider Safety Awareness among Motorcycle Users in Malaysia. *International Journal of Vehicle Structures & Systems*, 8(3). <https://doi.org/10.4273/IJVSS.8.3.06>
- Sivasankar, S., Karmegam, K., Shamsul Bahri, M. T., Naeini, H. S., & Kulanthayan, S. (2014). A review on children safety system for underbone motorcycle. *International Journal of Crashworthiness*, 19(1), 18–26. <https://doi.org/10.1080/13588265.2013.818605>
- Sudhakar, R. (2022). Application and advantages of casting process. *South Asian Academic Research Journals*, 75.
- Tosi, J. D., Poó, F. M., Ledesma, R. D., & Firsenko, E. (2021). Safety of child passengers who ride to school on a motorcycle: An observational study in two Argentine cities. *IATSS Research*, 45(2), 176-181. <https://doi.org/10.1016/j.iatssr.2020.08.004>
- United Nations Economic Commission for Europe. (2012). *Uniform provisions concerning the approval of enhanced child restraint systems used on board of motor vehicles (UN Regulation No. 129)*. <https://unece.org/transport/vehicle-regulations-wp29/standards/un-regulations-121-140>
- Yousif, M. T., Sadullah, A. F. M., & Kassim, K. A. A. (2020). A review of behavioural issues contribution to motorcycle safety. *IATSS Research*, 44(2), 142-154.